



Products FSEM21/31 and FSEK21/31 or FSEM20/30 and FSEK20/30 with FSE-B21

## Frequency Range Extension of Spectrum Analyzers with Harmonic Mixers

### Application Note

This application note describes the principle of harmonic mixing and the requirements to be met by spectrum analyzers and external mixers.



### **Contents**

|   |  |    |
|---|--|----|
| 1 | Introduction .....   | 2  |
| 2 | Fundamentals .....   | 3  |
|   | Waveguides .....   | 3  |
|   | Harmonic Mixing .....  | 5  |
|   | Signal Identification .....                                      | 8  |
|   | Characteristics of Mixers .....                                  | 11 |
|   | Spectrum Analyzer Requirements and their Realization in FSE..... | 12 |
|   | Measurement Hints .....  | 14 |
| 3 | Operation of External Mixers on FSE .....                        | 15 |
| 4 | References.....  | 18 |
| 5 | Ordering Information .....                                       | 18 |

### **1 Introduction**

The growing number of applications using wireless signal transmission, eg radiocommunication or collision avoidance systems, calls for an ever increasing number of frequencies. Since frequency requirements can no longer be met by the lower frequency bands alone, frequencies in the millimeter range are used to a growing extent. So this frequency range is not only employed by military users but opened up also for civil applications. So far, the frequencies up to 110 GHz have been of main interest. However, with demands made on harmonic suppression getting higher and EMC directives becoming more stringent (eg FCC CFR47 Part 15), this frequency limit is shifted to 200 GHz.

The frequency range above 40 to 50 GHz is covered by spectrum analyzers usually by means of external mixers because the fundamental mixing commonly employed in the lower frequency range is too complex and expensive or required components such as preselectors are not available.

This application note describes the principle of harmonic mixing and the criteria to be taken into account.

## 2 Fundamentals

### Waveguides

Wired signal transmission in the millimeter range is preferably realized by means of waveguides because they offer low attenuation and high reproducibility. Unlike coaxial cables, the frequency range in which waveguides can be used is limited also towards lower frequencies (highpass filter characteristics). Wave propagation in the waveguide is not possible below a certain cutoff frequency where attenuation of the waveguide is very high. Beyond a certain upper frequency limit, several wave propagation modes are possible so that the behaviour of the waveguide is no longer unambiguous. In the unambiguous range of a rectangular waveguide, only  $H_{10}$  waves are capable of propagation. The following formula applies to the lower cutoff frequency  $f_{c,1}$ , from which such waves are capable of propagation:

$$f_{c,1} = \frac{c}{2 \cdot a \cdot \sqrt{\epsilon_r}} \quad (\text{Equation 2-1})$$

where  $f_{c,1}$  Lower cutoff frequency (in Hz)  
 $c$  Velocity of light (in m/s)  
 $a$  Length of larger dimension of waveguide (in m)  
 $\epsilon_r$  Dielectric constant of medium in waveguide (= 1 for air)

From a limit frequency of  $f_{c,2}$ , the  $H_{01}$  wave can propagate in addition to the  $H_{10}$  wave.  $f_{c,2}$  is therefore the upper limit frequency of the unambiguous range. The following applies:

$$f_{c,2} = \frac{c}{2 \cdot b \cdot \sqrt{\epsilon_r}} \quad (\text{Equation 2-2})$$

where  $f_{c,2}$  Upper limit frequency (in Hz)  
 $b$  Length of smaller dimension of waveguide (in m)

Usually, a ratio of  $a/b = 2$  of the edge lengths is selected, so that  $f_{c,2} = 2 \cdot f_{c,1}$ .

Because of the high wave attenuation near the lower cutoff frequency  $f_{c,1}$ , and to allow for mechanical tolerances, the following transmission range is usually selected in practice [1]:

$$1.25 \cdot f_{c,1} \leq f \leq 1.9 \cdot f_{c,1} \quad (\text{Equation 2-3})$$

The dimensions of rectangular and circular waveguides are defined by international standards such as 153-IEC for various frequency ranges. These frequency ranges are also referred to as waveguide bands. They are designated using different capital letters depending on the standard. Table 2-1 provides an overview of the different waveguide bands together with the designations of the associated waveguides and flanges.

For rectangular waveguides, which are mostly used in measurements, harmonic mixers with matching flanges are available. For connecting harmonic mixers to circular waveguides, transitions are to be used whose attenuation has to be taken into account in the evaluation of results.

## ***Frequency Range Extension of Spectrum Analyzers***

Table 2-1 Waveguide bands and associated waveguides

| Band | Frequency<br><br>in GHz | Designations |       |         |                | Internal dimensions of waveguide |                | Designations of frequently used flanges |                                  |                                     |
|------|-------------------------|--------------|-------|---------|----------------|----------------------------------|----------------|---|----------------------------------|-------------------------------------|
|      |                         | MIL-W-85     | EIA   | 153-IEC | RCSC (British) | in mm                            | in inches      | MIL-F-3922                              | UG-XXX /U equivalent (reference) | Remarks                             |
| Ka   | 26.5 - 40.0             | 3-006        | WR-28 | R320    | WG-22          | 7.11 x 3.56                      | 0.280 x 0.140  | 54-003<br>68-002<br>67B-005             | UG-599 /U<br>-<br>UG-381 /U      | Rectangular<br>Rectangular<br>Round |
| Q    | 33.0 - 50.0             | 3-010        | WR-22 | R400    | WG-23          | 5.69 x 2.84                      | 0.224 x 0.112  | 67B-006                                 | UG-383 /U                        | Round                               |
| U    | 40.0 - 60.0             | 3-014        | WR-19 | R500    | WG-24          | 4.78 x 2.388                     | 0.188 x 0.094  | 67B-007                                 | UG-383 /U-M                      | Round                               |
| V    | 50.0 - 75.0             | 3-017        | WR-15 | R620    | WG-25          | 3.759 x 1.879                    | 0.148 x 0.074  | 67B-008                                 | UG-385 /U                        | Round                               |
| E    | 60.0 - 90.0             | 3-020        | WR-12 | R740    | WG-26          | 3.099 x 1.549                    | 0.122 x 0.061  | 67B-009                                 | UG-387 /U                        | Round                               |
| W    | 75.0 - 110.0            | 3-023        | WR-10 | R900    | WG-27          | 2.540 x 1.270                    | 0.100 x 0.050  | 67B-010                                 | UG-383 /U-M                      | Round                               |
| F    | 90.0 - 140.0            | 3-026        | WR-08 | R1200   | WG-28          | 2.032 x 1.016                    | 0.080 x 0.040  | 67B-M08 /<br>74-001                     | UG-383 /U-M                      | Round,<br>pin contact               |
| D    | 110.0 - 170.0           | 3-029        | WR-06 | R1400   | WG-29          | 1.651 x 0.826                    | 0.065 x 0.0325 | 67B-M06 /<br>74-002                     | UG-383 /U-M                      | Round,<br>pin contact               |
| G    | 140.0 - 220.0           | 3-032        | WR-05 | R1800   | WG-30          | 1.295 x 0.635                    | 0.051 x 0.0255 | 67B-M05 /<br>74-003                     | UG-383 /U-M                      | Round,<br>pin contact               |
| Y    | 170.0 - 260.0           |              | WR-04 | R2200   | WG-31          | 1.092 x 0.5461                   | 0.043 x 0.0215 | 67B-M04 /<br>74-004                     | UG-383 /U-M                      | Round,<br>pin contact               |
| J    | 220.0 - 325.0           |              | WR-03 | R2600   | WG-32          | 0.8636 x 0.4318                  | 0.034 x 0.017  | 67B-M03 /<br>74-005                     | UG-383 /U-M                      | Round,<br>pin contact               |

### Harmonic Mixing

In harmonic mixers, a harmonic of the local oscillator (LO) is used for signal conversion to a lower intermediate frequency (IF). The advantage of this method is that the frequency range of the local oscillator may be much lower than with fundamental mixing, where the LO frequency must be of the same order (with low IF) or much higher (with high IF) than the input signal (RF). Microwave spectrum analyzers use harmonic mixing also in the fundamental frequency range, FSEK for example from 26.5 GHz. To ensure image- and spurious-free spectrum display in the fundamental frequency range, a tracking preselection is provided at the RF input of the spectrum analyzer. In this way, signals are displayed at the desired frequency only. Image-frequency signals, which the mixer is not capable of distinguishing from signals at the desired frequency, are suppressed by the preselector. Preselection is not commonly used with external harmonic mixers because of the high frequencies involved. Preselection would be very costly in this case and hardly possible to realize at extremely high frequencies.

Fig. 2-1 shows the test setup for measurements using an external harmonic mixer. The mixer is fed a high-level LO signal. The harmonics generated in the mixer because of its nonlinearity are used for conversion.

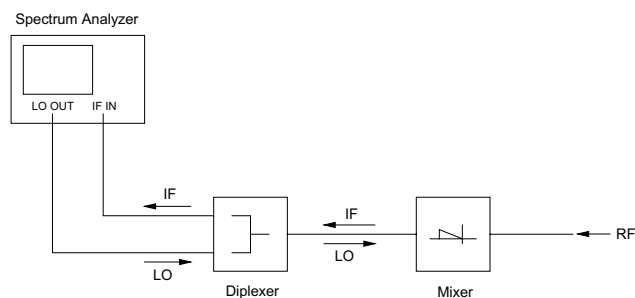

Fig. 2-1: Test setup for measurements using an external two-port mixer

The signal converted to the IF is coupled out of the line which is also used for feeding the LO signal. Because of the great frequency spacing between the LO and the IF signal, the two signals can be separated by means of a simple diplexer. The diplexer may be realized as part of the mixer or the spectrum analyzer, or as a separate component. Mixers with an integrated diplexer are also referred to as three-port mixers, mixers without diplexers as two-port mixers. To enable the use of both types of mixer, FSEM and FSEK offer a separate IF input as well as an integrated diplexer.

The LO path of harmonic mixers often contains a lowpass filter for the suppression of harmonics of the incoming LO signal. This is to prevent LO harmonics to be superimposed on the mixer-generated harmonics. Depending on the phase of the harmonics, this may cause blanking, which leads to higher conversion loss or produces notches in the frequency response characteristic. When selecting an external mixer, therefore, care should be taken that the limit frequency of the integrated lowpass filter is higher than the maximum LO frequency of the spectrum analyzer.

The RF signal applied to the input of the external mixer together with its harmonics is mixed with all harmonics of the LO signal. The mixer products that fall within the IF of the spectrum analyzer are displayed. They must fulfil the following criterion:

## Frequency Range Extension of Spectrum Analyzers

---

$$|m \cdot f_{LO} \pm n \cdot f_{RF}| = f_{IF} \quad (\text{Equation 2-4})$$

where  $m, n = 1, 2, \dots$

$f_{LO}$  Frequency of LO signal (in Hz)

$f_{RF}$  Frequency of input signal (in Hz)

$f_{IF}$  Intermediate frequency (in Hz)

The local oscillator of FSEM and FSEK is tunable between 7.5 and 15.2 GHz. The intermediate frequency is 741.4 MHz. For an input signal with a frequency of 39 GHz, the criterion according to equation 2-4 is fulfilled for the LO frequencies listed in Table 2-2.

The variable  $m$  corresponds to the order of the harmonic of the LO signal by which the input signal is converted to the IF. The criterion is fulfilled twice for each harmonic. The input signal is represented as the upper sideband (normal position) and also as the lower sideband (inverted position) of the local oscillator signal. Components with  $n \neq 1$  are harmonics of the input signal that are generated, for example, in the mixer. It can be seen that these harmonics are converted to the desired IF only by LO harmonics of a comparatively high order  $m$ . If the level of the input signal is well below the 1 dB compression point of the mixer, such components have a markedly lower level since the harmonics of the input signal are sufficiently attenuated with respect to the fundamental and in addition the conversion loss of the mixer increases with increasing order  $m$ . Therefore, only responses with  $n \leq 4$  are listed in Table 2-2. While components with higher  $m$  and  $n$  exist, they can be neglected because of their low level.

Table 2-2: LO frequencies for which the criterion according to equation 2-4 is fulfilled ( $f_{IF} = 741.4$  MHz,  $n \leq 4$ ,  $m \leq 12$ )

| $m$ | $n$ | $f_{LO} / \text{GHz}$ | $m$ | $n$ | $f_{LO} / \text{GHz}$ | $m$ | $n$ | $f_{LO} / \text{GHz}$ |
|-----|-----|-----------------------|-----|-----|-----------------------|-----|-----|-----------------------|
| 3   | 1   | 12.7529               | 8   | 2   | 9.6573                | 10  | 3   | 11.6259               |
| 3   | 1   | 13.2471               | 8   | 2   | 9.8427                | 10  | 3   | 11.7741               |
| 4   | 1   | 9.5647                | 8   | 3   | 14.5323               | 11  | 3   | 10.5690               |
| 4   | 1   | 9.9354                | 8   | 3   | 14.7177               | 11  | 3   | 10.7038               |
| 5   | 1   | 7.6517                | 9   | 2   | 8.5843                | 11  | 4   | 14.1144               |
| 5   | 1   | 7.9483                | 9   | 2   | 8.7490                | 11  | 4   | 14.2492               |
| 6   | 2   | 12.8764               | 9   | 3   | 12.9176               | 12  | 3   | 9.6882                |
| 6   | 2   | 13.1236               | 9   | 3   | 13.0824               | 12  | 3   | 9.8118                |
| 7   | 2   | 11.0369               | 10  | 2   | 7.7259                | ... | ... |                       |
| 7   | 2   | 11.2488               | 10  | 2   | 7.8741                |     |     |                       |

Spectrum analyzers however display the received spectrum not versus the LO frequency but versus the input frequency. For this, the user has to enter on the spectrum analyzer the order  $m'$  of the harmonic by which the input signal is to be converted. For the representation of signals in the lower sideband at the correct frequency  $f_{RF}'$ , the following equation applies (derived from equation 2-4):

$$f_{RF}' = m' \cdot f_{LO} - f_{IF} \quad (\text{Equation 2-5})$$

where  $m'$  Harmonic set by user

$f_{RF}'$  Frequency at which a spectral component is displayed on the analyzer (in Hz)

The LO frequency  $f_{LO}$ , which is required for conversion of a signal in the lower sideband, is obtained from equation 2-4 as follows:

## Frequency Range Extension of Spectrum Analyzers

---

$$f_{LO} = \frac{f_{IF} + n \cdot f_{RF}}{m} \quad (\text{Equation 2-6})$$

By substituting equation 2-6 in equation 2-5, the following is obtained for  $f_{RF}'$ :

$$f_{RF}' = m' \cdot \frac{f_{IF} + n \cdot f_{RF}}{m} - f_{IF} \quad (\text{Equation 2-7})$$

The following applies to components converted as the lower sideband by means of a harmonic of the order  $m = m'$ :

$$f_{RF}' = n \cdot f_{RF} \quad (\text{Equation 2-8})$$

Such components are therefore represented at the correct frequency. For image frequency response, the following corresponding equations apply:

$$f_{LO} = \frac{n \cdot f_{RF} - f_{IF}}{m} \quad (\text{Equation 2-9})$$

and

$$f_{RF}' = m' \cdot \frac{n \cdot f_{RF} - f_{IF}}{m} - f_{IF} \quad (\text{Equation 2-10})$$

The following is then obtained for  $m = m'$ :

$$f_{RF}' = n \cdot f_{RF} - 2 \cdot f_{IF} \quad (\text{Equation 2-11})$$

If  $m = 3$  is selected, the spectrum displayed on the analyzer contains components at the frequencies listed in Table 2-3 (see also Fig. 2-2 on next page). Components lying within the corresponding waveguide band (Ka band in this case) are highlighted grey.

Table 2-3: Displayed components for  $m' = 3$  (lower sideband,  $f_{IF} = 741.4$  MHz); sinewave input signal with  $f_{RF} = 39$  GHz

| <i>m</i> | <i>n</i> | $f_{LO} / \text{GHz}$ | $f_{RF}' / \text{GHz}$ | <i>m</i> | <i>n</i> | $f_{LO} / \text{GHz}$ | $f_{RF}' / \text{GHz}$ | <i>m</i> | <i>n</i> | $f_{LO} / \text{GHz}$ | $f_{RF}' / \text{GHz}$ |
|----------|----------|-----------------------|------------------------|----------|----------|-----------------------|------------------------|----------|----------|-----------------------|------------------------|
| 3        | 1        | 12.7529               | 37.5172                | 8        | 2        | 9.6573                | 28.2306                | 10       | 3        | 11.6259               | 34.1362                |
| 3        | 1        | 13.2471               | 39.0000                | 8        | 2        | 9.8427                | 28.7866                | 10       | 3        | 11.7741               | 34.5810                |
| 4        | 1        | 9.5647                | 27.9526                | 8        | 3        | 14.5323               | 42.8556                | 11       | 3        | 10.5690               | 30.9655                |
| 4        | 1        | 9.9354                | 29.0647                | 8        | 3        | 14.7177               | 43.4116                | 11       | 3        | 10.7038               | 31.3699                |
| 5        | 1        | 7.6517                | 22.2138                | 9        | 2        | 8.5843                | 25.0115                | 11       | 4        | 14.1144               | 41.6019                |
| 5        | 1        | 7.9483                | 23.1034                | 9        | 2        | 8.7490                | 25.5057                | 11       | 4        | 14.2492               | 42.0063                |
| 6        | 2        | 12.8764               | 37.8879                | 9        | 3        | 12.9176               | 38.0115                | 12       | 3        | 9.6882                | 28.3233                |
| 6        | 2        | 13.1236               | 38.6293                | 9        | 3        | 13.0824               | 38.5057                | 12       | 3        | 9.8118                | 28.6940                |
| 7        | 2        | 11.0369               | 32.3694                | 10       | 2        | 7.7259                | 22.4362                | ...      | ...      |                       |                        |
| 7        | 2        | 11.2488               | 33.0049                | 10       | 2        | 7.8741                | 22.8810                |          |          |                       |                        |

The input signal converted by means of the 3<sup>rd</sup> harmonic of the LO signal is displayed at the correct frequency  $f_{RF}' = 39$  GHz. The image signal is displayed below this signal at a spacing of  $2 \cdot f_{IF} = 1.4828$  GHz (cf. Equation 2-11).

## Frequency Range Extension of Spectrum Analyzers

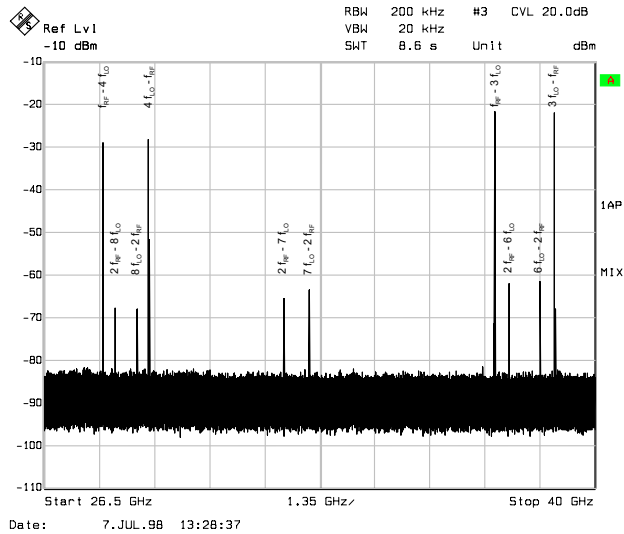

Fig. 2-2: Spectrum of 39 GHz CW signal recorded with harmonic mixer

The above example illustrates that even a simple sinewave signal produces a large number of responses. If the input signal itself contains several spectral components, intermodulation products may be generated in the mixer in addition to harmonics, such products too being converted to the IF. If the input signal consists of two sinewave carriers, the following applies:

$$\left| m \cdot f_{LO} \pm \left| n \cdot f_{RF,1} \pm k \cdot f_{RF,2} \right| \right| = f_{IF} \quad (\text{Equation 2-12})$$

where  $k, n$  0, 1, 2, ...

$m$  1, 2, ...

$f_{LO}$  Frequency of LO signal (in Hz)

$f_{RF,1}, f_{RF,2}$  Frequencies of input signals (in Hz)

$f_{IF}$  Intermediate frequency (in Hz)

The number of components increases considerably. It is advisable, therefore, to make use of the highpass filter characteristic of waveguides to suppress unwanted input signals.

### Signal Identification

In the previous example, the type of input signal was known, and so it was easy to distinguish the true (or wanted) displayed signal from unwanted mixer products obtained as a result of image frequency response and mixing by other harmonics.

Frequently, the spectrum to be measured is not known however so that criteria have to be found to distinguish unwanted mixer products from spectral components that are true components of the input signal. From equation 2-10 it can be seen that for each mixture product there exist image frequencies which appear at a spacing of  $f_{IF} \cdot (m'/m+1)$  below the mixture product. For  $m = m'$ , the spacing is exactly  $2 \cdot f_{IF}$  (equation 2-11). The same applies to harmonics of the input signal, ie to  $n \neq 1$ . However, since the frequency ranges of the standardized waveguide bands are considerably smaller than one octave, such mixer products will not become apparent even if the full band is displayed.



## Frequency Range Extension of Spectrum Analyzers

Based on this criterion, the following algorithm can be realized: Apart from the actual test sweep, in which the lower sideband is defined as "wanted", a reference sweep is performed. For the reference sweep, the frequency of the LO signal is tuned such that the user-selected harmonic of the LO signal (order  $m'$ ) is shifted downwards by  $2 \cdot f_{IF}$  relative to the test sweep (see Fig. 2-3).

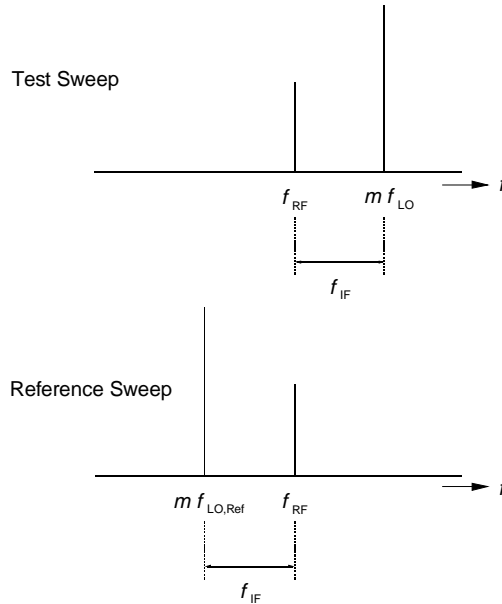

Fig. 2-3: Signal identification by means of reference sweep

For this reference sweep, the upper sideband is the wanted sideband. Equation 2-5 is therefore modified to take the following form:

$$f_{RF,Ref}' = m' \cdot f_{LO,Ref} + f_{IF} \quad (\text{Equation 2-13})$$

where  $f_{RF,Ref}'$  Frequency, at which a spectral component is displayed in reference sweep (in Hz)

$f_{LO,Ref}$  LO frequency in reference sweep (in Hz)

Equation 2-6 is modified accordingly to:

$$f_{LO,Ref} = \frac{n \cdot f_{RF} - f_{IF}}{m} \quad (\text{Equation 2-14})$$

By substituting equation 2-14 in equation 2-13, the following results:

$$f_{RF,Ref}' = m' \cdot \frac{n \cdot f_{RF} - f_{IF}}{m} + f_{IF} \quad (\text{Equation 2-15})$$

The following applies to image frequency responses:

$$f_{LO,Ref} = \frac{n \cdot f_{RF} + f_{IF}}{m} \quad (\text{Equation 2-16})$$

and therefore:

$$f_{RF,Ref}' = m' \cdot \frac{n \cdot f_{RF} + f_{IF}}{m} + f_{ZF} \quad (\text{Equation 2-17})$$

By selecting  $m' = m$  in equation 2-17, it will be seen that, unlike the test sweep, image frequency responses are displayed at a spacing of  $2 \cdot f_{IF}$  above the actual input signal (cf. equation 2-8). This allows image

## Frequency Range Extension of Spectrum Analyzers

frequency responses and other unwanted mixer products to be identified (see Fig. 2-4).

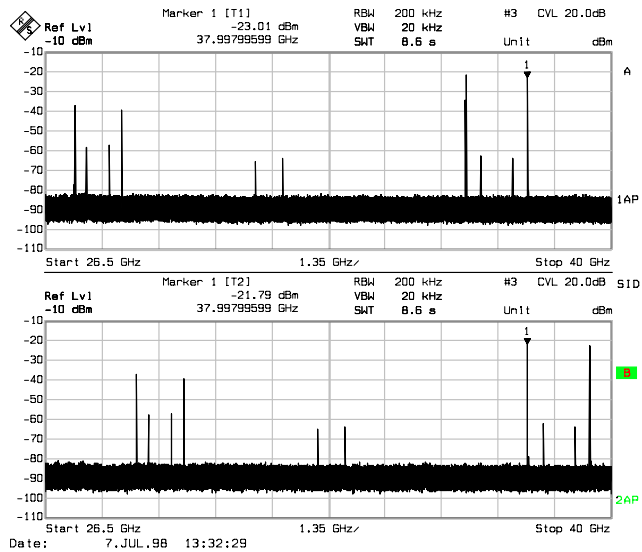

Fig. 2-4: Test sweep (top) and reference sweep (bottom)  
Input signal with  $f_{RF} = 38$  GHz

A true signal should be displayed at the same frequency in the test sweep and the reference sweep, ie  $f_{RF}' = f_{RF,Ref}'$ . If  $m'$  is the same for both sweeps, the following is obtained for the LO frequency  $f_{LO,Ref}$  to be set for the reference sweep:

$$f_{LO,Ref} = f_{LO} - \frac{2 \cdot f_{IF}}{m'} \quad (\text{Equation 2-18})$$

Apart from this method of signal identification by variation of the LO frequency, it is possible to vary the level of the input signal to identify displayed components.

By varying the level of the input signal by  $\Delta L$  / dB, the level of displayed true components will vary to the same extent. The levels of intermodulation products and harmonics generated in the mixer, on the other hand, will vary according to their order  $n$ , ie a variation of the input level by 1 dB will cause a level variation of  $n$  dB. This is subject to the condition that such intermodulation products and harmonics are generated exclusively in the mixer. Care must be taken, therefore, that the input signal is free from such products. Moreover, it must be ensured that the IF input of the spectrum analyzer is not overloaded.

Since the input level can be varied only by the user, this method, unlike signal identification by varying the LO frequency, is not suitable for being implemented in a spectrum analyzer.

### **Characteristics of Mixers**

Harmonic mixers are divided into single-diode and double-diode mixers. Most commercially available mixers are single-diode mixers, because these are easier to realize. Single-diode mixers basically operate with both even and odd harmonics of the LO signal.

The disadvantage of this concept is that it requires biasing. To this end, the mixer is fed with a DC voltage via the LO line. The DC voltage is to be adjusted frequency-dependent for minimum conversion loss of the mixer, which complicates automatic measurements at different frequencies.

Double-diode mixers are more complex but require no biasing; they are therefore also referred to as zero-bias mixers. To attain minimum conversion loss, such mixers should normally be operated with even harmonics.

Moreover, the following characteristics should be taken into account in selecting the mixer:

- required as well as maximum permissible LO power,
- permissible LO frequency range,
- conversion loss,
- frequency response of conversion loss across small frequency spans,
- order of harmonic for which the specified conversion loss is valid,
- sensitivity of conversion loss to changes of LO level,
- permissible intermediate frequency.

In addition to the optimum LO level, at which minimum conversion loss is obtained, the maximum LO power is normally specified at which the mixer can be used without any damage being caused. Because of the lowpass filter contained in the LO path of the mixer (see section "Harmonic mixing"), the usable LO frequency range must be taken into account. If the mixer incorporates a diplexer, it must further be ensured that the IF frequency of the spectrum analyzer is within the bandwidth of the IF port of the mixer.

To ensure a small level error, not only the conversion loss should be as small as possible for high sensitivity, but a continuous frequency response is equally important. Narrowband notches or steps of the frequency response can only with difficulty be taken into account in the level correction of the spectrum analyzer.

The specified conversion loss applies only to a specific order of the harmonic. If a different harmonic is selected on the spectrum analyzer, level correction by means of the values supplied for the frequency-dependent conversion loss will lead to erroneous results. To obtain reproducible results, dependence of conversion loss on the LO level should be as small as possible.

## Spectrum Analyzer Requirements and their Realization in FSE

### Order of LO Harmonic

To obtain low conversion loss of the external mixer, the order of the harmonic used for converting the input signal should be as low as possible. For this, the frequency range of the local oscillator must be as high as possible. Spectrum Analyzers FSEM and FSEK fully meet this requirement with an LO frequency range of 7.5 to 15.2 GHz.

A wide LO frequency range and thus a low order  $m'$  is of advantage also in phase noise measurements of microwave signals.

Multiplication of the signal causes an increase of the phase noise by the multiplication factor. For a harmonic of the order  $m'$ , SSB phase noise is obtained as follows [2]:

$$L_{PNm'}(f_{off}) = L_{LO}(f_{off}) + 20 \lg(m') \text{dB} \quad (\text{Equation 2-19})$$

where  $L_{PNm'}(f_{off})$  SSB phase noise of harmonic of the order  $m'$  at a carrier offset  $f_{off}$  (in dBc(Hz))

$L_{LO}(f_{off})$  SSB phase noise of LO signal at a carrier offset  $f_{off}$  (in dBc(Hz))

Fig. 2-5 shows the typical SSB phase noise of the local oscillator of FSE.

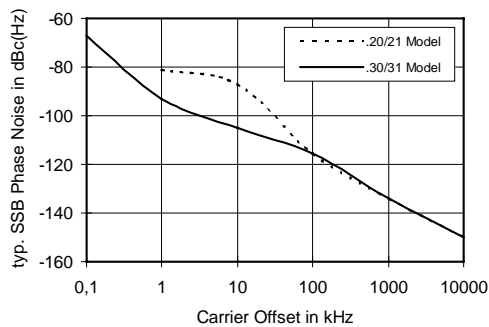

Fig. 2-5: Typical SSB phase noise of local oscillator of FSEM / FSEK

The overall noise figure of the system, which consists of a spectrum analyzer and external mixer, is composed as follows: noise figure at IF input of spectrum analyzer, plus conversion loss of mixer, plus feedthrough of LO SSB noise to the intermediate frequency. Sensitivity is usually specified as **Displayed Average Noise Level** ( $L_{DAN}$ ) for a specific IF bandwidth. The following applies:

$$L_{DAN} = -174 \text{ dBm(Hz)} + a_{CVL} + NF_{SA} + (10 \cdot \lg \frac{B_{IF}}{\text{Hz}}) \text{dB} - 2,5 \text{ dB} \quad (\text{Equation 2-20})$$

where  $L_{DAN}$  Displayed average noise level (in dBm)

$a_{CVL}$  Conversion loss of external mixer (in dB)

$NF_{SA}$  Noise figure of analyzer at IF input (in dB)

$B_{IF}$  Noise bandwidth of IF filter (in Hz)

The value of  $-174 \text{ dBm}$  corresponds to the noise power over 1 Hz bandwidth of a  $50 \Omega$  resistance at an ambient temperature of 290 K. The correction value of 2.5 dB is necessary because of averaging of logarithmic level values.

FSEM and FSEK have a noise figure of typically 7.5 dB at their IF inputs.

## Frequency Range Extension of Spectrum Analyzers

The effects of broadband noise of the local oscillator are not taken into account in equation 2-20. Such effects may lead to further reduction of sensitivity. If the IF input is open and the two-port mixer is selected, the noise displayed on FSEM and FSEK is about 3 dB higher than with a three-port mixer.

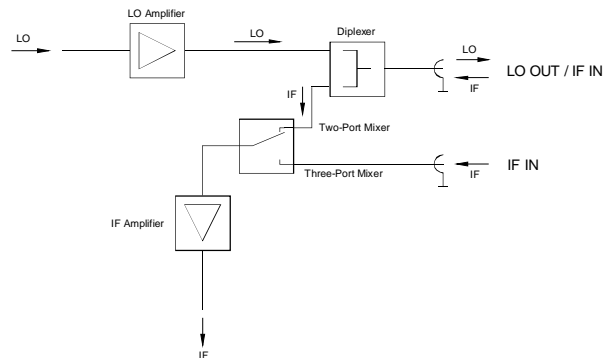

Fig. 2-6: LO amplifier and diplexer in FSE

If the signal path for a two-port mixer is selected, broadband noise at the output of the LO amplifier is applied directly to the IF path in the diplexer and leads to a higher displayed noise as described above (see Fig. 2-6).

### Intermediate Frequency

The higher the IF frequency of the spectrum analyzer, the greater the spacing at which image frequency response is displayed on the frequency axis (cf. equation 2-11). Mixer products generated by conversion of the fundamental of the input signal ( $n = 1$  in equation 2-4) by means of harmonics of the LO signal have a level clearly above that of other mixer products and are therefore easy to identify.

For a single modulated or unmodulated input signal displayed on the frequency axis, an image-free range of  $2 \cdot f_{IF}$  is obtained around this signal in which no signal identification is necessary. Because of the high IF of 741.4 MHz, the image-free range for FSEM and FSEK is 1.4828 GHz. This is sufficient for many applications, doing away with the need for signal identification.

### Local Oscillator Level

The level of the LO signal must be sufficiently high to ensure proper functioning of the mixer, taking into account the loss due to the cable for feeding the LO signal to the mixer. The frequency response of the LO level should be as flat as possible.

If a two-port mixer is used, it is of advantage if a diplexer is integrated in the spectrum analyzer. This does away with the need for an external diplexer, and thus no extra insertion loss needs to be taken into account in level measurements.

FSEM and FSEK both feature an internal diplexer as well as an additional IF signal input ("IF IN" connector, see Fig. 2-6). This allows the use of either two-port or three-port mixers without the need for any external components.

### **Signal Identification Methods**

Apart from hardware requirements, signal identification methods play an important role for the efficient use of harmonic mixers. In FSEM and FSEK, the method described in section "Signal Identification" is implemented. The test and the reference sweep can be compared "manually" by the user and also automatically. Unwanted mixer products are blanked in the displayed spectrum. This enables fast, continuous signal identification.

### **Measurement Hints**

To obtain accurate and reproducible results, the following points should be observed:

- A low-loss cable with a flat frequency response should be used for feeding the LO signal to the mixer. The conversion loss of the mixer is normally specified for a defined LO level. It is therefore important to maintain this level at the LO port of the mixer in order to achieve the desired accuracy.
- In level correction on the spectrum analyzer, the insertion loss of the cable used for tapping the IF signal is to be taken into account.
- If an external diplexer is used for connecting a two-port mixer, the insertion loss of the IF path of the diplexer is to be taken into account in level correction on the spectrum analyzer.

Harmonic mixers frequently have a low return loss (typ. VSWR > 2.5:1). If in addition the DUT has poor output matching, the actual conversion loss may markedly deviate from specified values. It is therefore expedient to insert an attenuator or isolator between the mixer and the DUT in order to increase measurement accuracy. However, the insertion loss caused by such a component will reduce the sensitivity of the spectrum analyzer and mixer setup. This insertion loss has also to be taken into account in level correction on the spectrum analyzer.

### 3 Operation of External Mixers on FSE

The operation of external mixers on FSE will be explained by means of the following example.

A sinewave signal with  $f = 14.5$  GHz is applied to the input of a multiplier. The spectrum at the output of the multiplier is to be measured in the range 52 to 60 GHz by means of FSE and a two-port mixer for the V band. The mixer used is a double-diode mixer. Its frequency-dependent conversion loss is stored in a file on the FSE hard disk (file name: "EXTMIX\_V").

First, the mixer is connected to the waveguide output of the signal source. The LO/IF port is connected to the "LO OUT / IF IN" connector of FSE using a low-loss coaxial cable.

External mixing is activated by:

➤ [ **INPUT : EXTERNAL MIXER** ] (1)

Then the BAND LOCK ON MODE is activated:

➤ [ **INPUT : EXTERNAL MIXER : BAND LOCK ON / OFF** ]. (2)

With

➤ [ **INPUT : EXTERNAL MIXER : SELECT BAND** ] (3)

the table with the parameters for the individual waveguide bands is called up. From this table the desired band, in this case band V, is selected.

➤ [ **INPUT : EXTERNAL MIXER : SELECT BAND : BAND** ] (4)  
Selection of band by means of cursor keys and ENTER

After selecting the band, the frequency-dependent conversion loss is to be activated. To this end, the file containing the conversion loss of the mixer used is selected.

➤ [ **INPUT : EXTERNAL MIXER : SELECT BAND : CONV LOSS TABLE** ] (5)  
Selection of file "EXTMIX\_V" with cursor keys and ENTER

The file contains all the required parameters, so that no further settings are necessary. The selected file remains stored for the selected band. If the same mixer is selected in later measurements, only steps 1 to 4 have to be executed.

After leaving the selection table with the key  $\hat{\uparrow}$  (menu up), a span is set automatically by which the complete V band is covered, ie 50 to 75 GHz. The frequency range to be investigated is set with

➤ [ **FREQUENCY START : 52 GHz** ]

and

➤ [ **FREQUENCY STOP : 60 GHz** ]

To ensure reliable signal identification by means of the AUTO ID function, the video bandwidth is reduced as follows:

➤ [ **SWEEP COUPLING : VIDEO BW MANUAL : 1 MHz** ]

The spectrum shown in Fig. 3-1 is obtained.

## Frequency Range Extension of Spectrum Analyzers

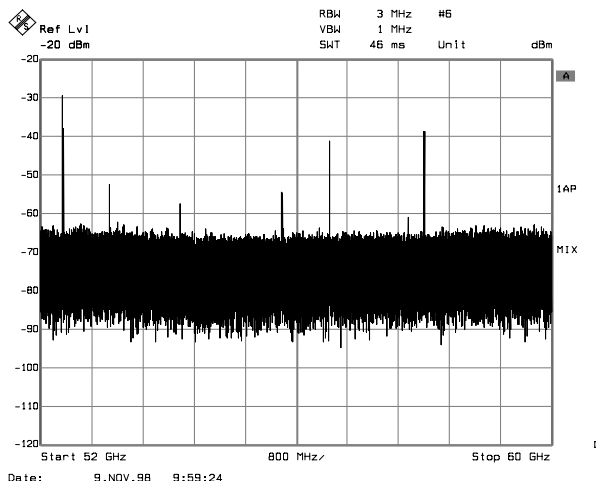

Fig. 3-1: Output spectrum of multiplier, measured by means of external mixer

To identify the true input signal, the AUTO ID function is activated:

➤ [ **INPUT** : EXTERNAL MIXER : SIGNAL ID : AUTO ID ]

AUTO ID operates on the principle described in section 2.3. In addition to the test sweep, a reference sweep is performed in which the LO frequency is shifted downwards in accordance with equation 2-18. The spectra measured in the two sweeps are compared with each other automatically and the result is displayed. Unwanted mixer products are blanked in the displayed trace. The display shown in Fig. 3-2 is obtained.

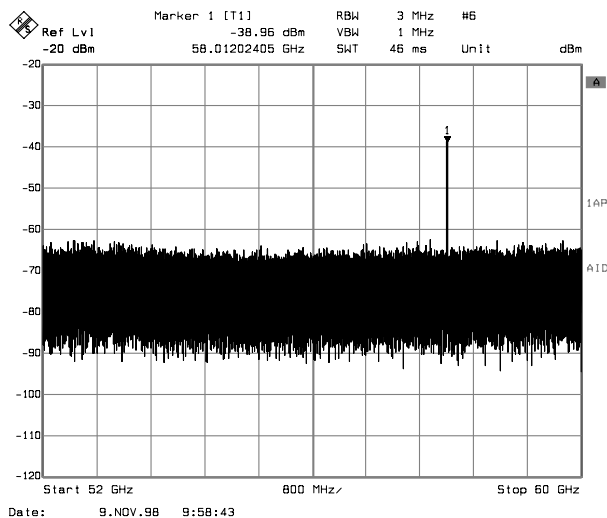

Fig. 3-2: Output spectrum of multiplier, measured by means of external mixer and AUTO ID function

Since the LO frequency is shifted downwards in the reference sweep, the mixer conversion loss may turn out to be different for the test and the reference sweep. The reasons for this are the LO output power of the spectrum analyzer varying with the frequency and the non-ideal characteristics of the mixer. A certain tolerance should therefore be allowed in the comparison of the signal levels of the test sweep and the reference sweep. The user can set this tolerance with:

➤ [ **INPUT** : EXTERNAL MIXER : SIGNAL ID : AUTO ID THRESHOLD : {value} dB ]



## ***Frequency Range Extension of Spectrum Analyzers***

---

The tolerance must be at least as large as the difference between the conversion losses obtained for the test sweep and the reference sweep. If this is not observed, the true input signal might be displayed with an incorrect level. In the above example, a tolerance of 5 dB was selected.

Mixer conversion loss is already taken into account in the display. Only the insertion loss  $a_0$  @ 741.4 MHz of the cable used for tapping the IF signal is to be taken into account in determining the signal level. The actual level of the input signal is higher by  $a_0$ .

### 4 References

- [1] Janssen, W.: Hohlleiter und Streifenleiter. Dr. Alfred Hüthig Verlag Heidelberg, 1977
- [2] Engelson, M.: Sideband noise measurement using the spectrum analyzer. Application note 26W-7047, Tektronix

### 5 Ordering Information

#### Spectrum Analyzer

|         |   |              |
|---------|---|--------------|
| FSEM 20 | (9 kHz to 26.5 GHz)                                 | 1080.1505.20 |
| FSEM 21 | (9 kHz to 26.5 GHz, with output for external mixer) | 1080.1505.21 |
| FSEM 30 | (20 Hz to 26.5 GHz)                                 | 1079.8500.30 |
| FSEM 31 | (20 Hz to 26.5 GHz, with output for external mixer) | 1079.8500.31 |
| FSEK 20 | (9 kHz to 40 GHz)                                   | 1088.1491.20 |
| FSEK 21 | (9 kHz to 40 GHz, with output for external mixer)   | 1088.1491.21 |
| FSEK 30 | (20 Hz to 40 GHz)                                   | 1088.3494.30 |
| FSEK 31 | (20 Hz to 40 GHz, with output for external mixer)   | 1088.3494.31 |

#### Required Accessories for FSEM / FSEK Models 20 / 30:

|         |                             |              |
|---------|-----------------------------|--------------|
| FSE-B21 | (Output for external mixer) | 1084.7243.02 |
|---------|-----------------------------|--------------|



ROHDE & SCHWARZ GmbH & Co. KG · Mühlhofstraße 15 · D-81671 München  
P.O.B. 80 14 69 · D-81614 München · Telephone +49 89 4129 -0 · Fax +49 89 4129 - 3777 · Internet: <http://www.rsd.de>